

Applications

For all types of industrial applications, such as compressors, pumps etc. as well as heating and sanitary applications.

Compensate for thermal elongation and misalignment.

Reduce vibrations, dampen noise and pressure surges in connection with engines, pumps, compressors, turbines etc.

Design

Teguflex C is a rubber expansion joint of very flexible construction. Because of its high convolution and the short building length, the expansion joint gets outstanding noise and vibration absorbing properties as well as a high expansion absorption in all directions.

The turnable flanges with threaded holes and the highly flexible bellow, makes the mounting of the expansion joint very simple.

Building length 100 mm.

Turnable flanges.

Teguflex® C

Expansion Joints DN 25-DN 150



Materials

Colour Label	Inner tube	Outer cover	Max temp. °C	Applications
Red	EPDM	EPDM	90°	Hot water, cooling water with salt solutions, chlorine solutions, esters and ketones.
Yellow	ECO	ECO	90°	Water, salt solutions, alkalis, mineral oils, vegetable or animal oils, oils aerosols, butane or propane gas, etc.
Double red HP	Spec. EPDM	Spec. EPDM	130°	Hot water, vapour, hot air etc. at temperatures up to 130°C.

Note: Other materials available. Please ask.

Pressure rating

Pressure	Temperature	Teguflex Pressure	Teguflex HP Pressure
Max. working pressure	70°C	10 bar	10 bar
	90°C	6 bar	10 bar
	130°C	-	6 bar
Test pressure	20°C	15 bar	15 bar
Burst pressure	20°C	>30 bar	>30 bar

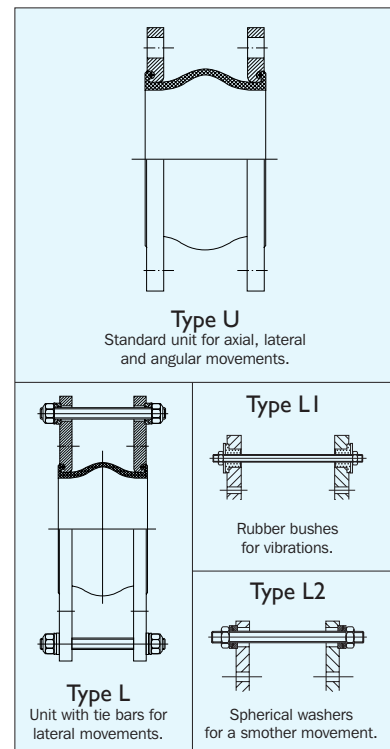

Teguflex C BL 100 DN 25-DN 150

Flange qualities

Yellow cromated steel flanges are supplied as standard, however other types are available: stainless steel, hot dipped galvanized, etc.

Flange measurements

DN 25-DN 150 DIN 2501 PN6/10/16

Note: Threaded holes! See table below (d).

(see Flange dimension table for details)

Other flange standards available. Please ask.

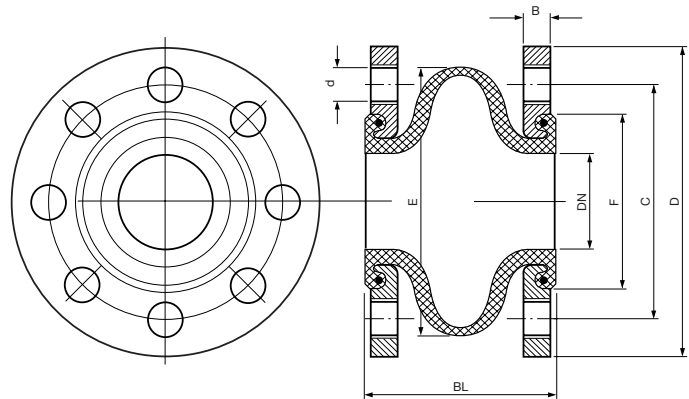

Dimensions and movements

DN mm	BL mm	Eff.cross-sectional area Q(cm ²)	(E) mm	(F) mm	(d)	Permissible movements				Max. vacuum		Weight		Spring Rates		
						Com- pression mm	Elon- gation mm	Lateral mm	An- gular	W/o support ring bar	With support ring bar	Incl. flange kg	Incl. Tie-rod flange kg	Com- pression Stiffness kg/cm	Elon- gation Stiffness kg/cm	Lateral Stiffness kg/cm
25/32	100	18/18	110	65	M16	30	20	30	15°	0.8	1.0	2.8	4.5	30	40	30
40	100	18	110	78	M16	30	20	30	15°	0.8	1.0	3.3	4.8	30	40	30
50	100	35	120	90	M16	30	20	30	15°	0.7	1.0	3.7	5.0	30	40	30
65	100	56	135	108	M16	30	20	30	15°	0.6	1.0	4.8	6.4	30	40	30
80	100	87	170	124	M16	30	20	30	15°	0.5	1.0	5.3	7.5	30	40	30
100	100	130	180	152	M16	30	20	30	15°	0.5	1.0	6.2	9.0	40	50	40
125	100	190	195	183	M16	30	20	30	15°	0.4	0.9	8.2	11.2	40	50	40
150	100	263	260	214	M20	30	20	30	15°	0.3	0.9	11.2	13.4	50	60	50

Note: Maximum values do not apply simultaneously. Stiffness values tolerance: +/- 20%.
Other dimensions available. Please ask.

Optional equipment

Vacuum rings, Flame guard, etc. are available.



Distributor:

Interflex Hose & Bellows Ltd. • www.integflex.co.uk
Ludlow Business Park • Ludlow • Shropshire • SY8 1XF • United Kingdom
Tel: +44 (0)1584 878500 • Fax: +44 (0)1584 878115 • Email: teguflex@integflex.co.uk